

### PROVEN DURABILITY.

The Prentice 2124 A-frame design is based on a clean, simple pedestal, fabricated from high strength steel. Heat treated, high alloy steel pins and aluminum-bronze pivot bushings maximize durability. Telescopic A-frame stabilizers with individual controls provide a strong footing in uneven terrain.

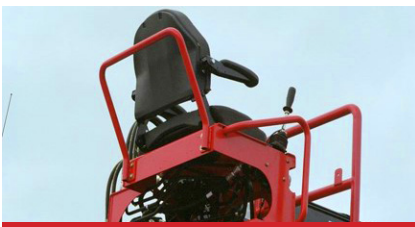

### OPERATOR COMFORT.

Operator platform features a large adjustable seat with padded armrests. Access ladders and hand grabs are positioned for maintaining "three point" contact. A front operator protection guard is standard.



### SMOOTH AND STRONG.

The 3,200 psi hydraulic system maximizes lift capacity and multi-functioning of the boom and grapple. The joystick-controlled valves and quick swing system provide a smooth, consistent, and controlled response.



### APPLICATION VERSATILITY.

Two A-frame height options allow for mountings in different applications and industries. Multiple grapple offerings include pulpwood, by-pass log and solid waste grapples. Several options developed over 60+ years provide maximum versatility.

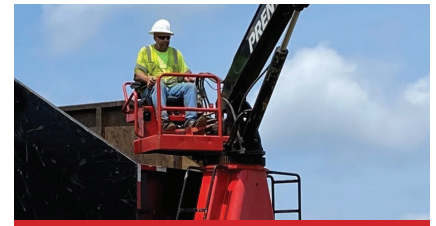

### RELIABLE ELECTRICAL.

An 8 circuit electrical collector provides electrical power for setting stabilizers while the optional 12 and 14 circuit collectors offer greater flexibility. Work light packages for stick boom and operator platform are optional. Optional telebooms feature thumb-switch proportional controls.

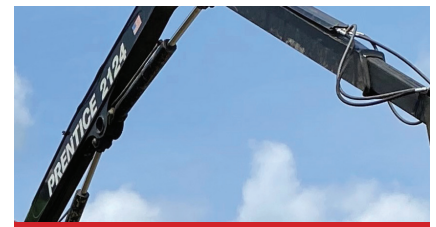

### LONG LASTING LEGACY.

Since 1956, Prentice knuckleboom loaders have built a legacy by listening to customers. Weiler Forestry continues to build on the 2124 which is fast, strong, light weight, and one of the smoothest loaders in the market.

# 2124 SPECIFICATIONS

<b>Maximum Flow @ 1650 rpm</b>	40 gpm	151 L/min	<b>22' STD Boom Max Lift</b>	9,325 lb	4230 kg	<b>Ground Clearance</b>	20"	50.8 cm
<b>Hydraulic Pressure</b>	3,200 psi	220 bar	<b>22' STD Boom Lift @ Full Reach</b>	3,329 lb	1510 kg	<b>Width (Stabilizers Retracted)</b>	8'3"	2.51 m
<b>Weight 22' STD Boom</b>	5,700 lb	2585 kg	<b>25' Teleboom Max Lift</b>	12,762 lb	5789 kg	<b>Width (Stabilizers Full Reach)</b>	10'2"	3.10 m
<b>Weight 25' Teleboom</b>	6,050 lb	2744 kg	<b>25' Teleboom Lift @ Full Reach</b>	2,592 lb	1176 kg	<b>Width (Stabilizers @ Gnd Level)</b>	9'4"	2.85 m

Base configuration includes: A-Frame, Boom and Stick, Telescoping Stabilizers, Loader Pump, Mounting Hardware, Grapple Knuckle, 8 Circuit Electrical Collector, 5 Pass Hydraulic Swivel, Access Ladder and Grab Handles, Operator Platform with Fold Down Seat and Armrests. All dimensions are for a 40" truck chassis frame height.

## HYDRAULICS

- Split flow tandem hydraulic pump
- Stacked hydraulic valve sections with mechanical joysticks
- Anti-cavitation valves with port reliefs
- Diagnostic ports located at control valves
- HD main and stick cylinders
- Aluminum hydraulic tank with filtered breather and sight gauge
- Pump mounting
  - Direct mounted PTO driven
  - Optional chassis mounted configuration
- Continuous rotation
- Ring and pinion gear set driven by an axial piston hydraulic motor through a planetary gearbox
- Hydraulic swivel with 5 passages for pressure, return and stabilizers
- High pressure hoses with wear resistant coating and ORS fittings
- Dual, spin on return filters
  - 2 nominal/10 absolute micron filter
  - 25 micron case drain filter

## OPERATOR PLATFORM

- Right side mounted platform with fold over seat with armrests
- Two mechanical joysticks and proportional teleboom controls
- Swing pedal with mechanical linkage
- Individual controls for activation of stabilizer
- Access to platform by single ladder

## STRUCTURES

- A-Frame pedestal design is formed high strength steel plate
- Telescopic A-frame stabilizers with individual platform controls
- Stabilizer legs made of high tensile steel tubing
- 22' STD Boom
  - Horizontal reach 22' (6.7 m)
  - Working height to boom tip 34' (10.3 m)
- 25' Teleboom
  - Horizontal reach 25' (7.6 m)
  - Working height to boom tip 37' (11.2 m)
- Welded high tensile steel boom
- Heat treated high alloy steel pins and aluminum-bronze pivot bushings
- Self-aligning bushings at both ends of main and stick boom cylinders
- Boom & cylinder pin bushings are greased through pins
- Castings at base end, stick end, and midpoint of main boom assembly

## OPTIONAL EQUIPMENT

- Multiple A-frame mounting configurations
- Multiple hydraulic installation and reservoir designs
- Multiple electrical circuit collector options (8, 12, 14 circuit collectors)
- Platform and boom lights
- A-Frame guards
- Seat belt kit
- Shutoff switch
- Service ladder (left hand mounted)
- Electric oil cooler (12V / 28 Amps)
- Main boom/stick valve kit (counterbalance valve)
- Hydraulic tank heater
- Pulpwood, by-pass log and solid waste grapples

Trailer Mounted Dimensions

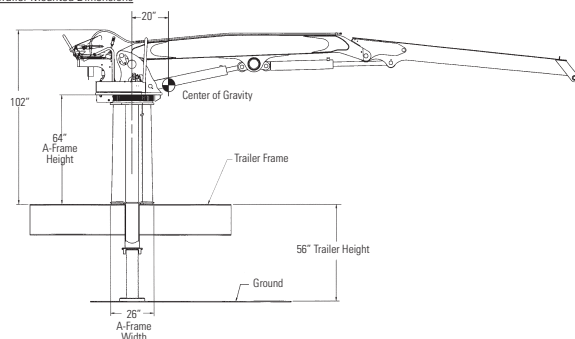

Truck Mounted Dimensions

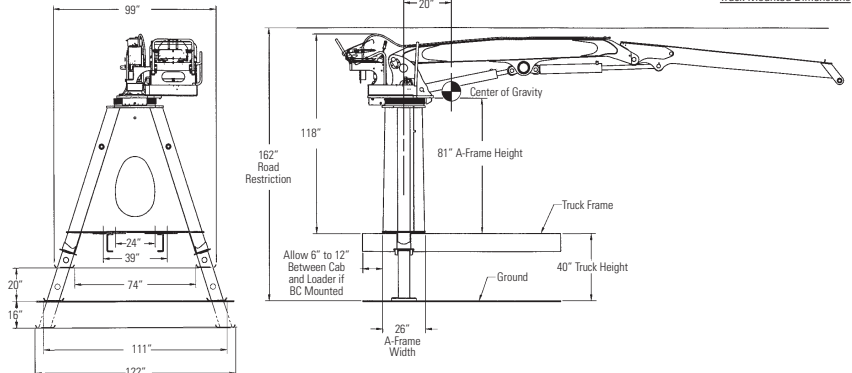

## SALES AND SERVICE

Sold and serviced exclusively through Weiler Forestry dealers worldwide

[WEILERFORESTRY.COM](http://WEILERFORESTRY.COM)

## WARRANTY

12 months standard warranty

Materials and specifications are subject to change without notice.  
Specifications adhere to DIN15018 B4, B5 and H3, H4.  
Featured machines and photos may include optional equipment. All rights reserved.

2124, SS (04-2023)